



GUSTOTEK™
technology meets passion

AUTHENTIC ITALIAN PASSION

OUR MISSION - EXCELLENCE

Gustotek is an innovative company born with the aim of spreading the culture of Italian fresh pasta all over the world by offering a system of professional equipment designed and produced according to the principles of Lean design & manufacturing.

The result is a product characterized by high technological content, attractive design and above all high reliability.



QUALITY AND RELIABILITY

The quality of Gustotek processes and products is the result of constant research and development, carried out since its foundation within the POLO DELLA MECCATRONICA of Rovereto, the Italian innovation center where every detail of the our machines is designed and developed.

DESIGN & TECHNOLOGY

Constantly evolving research, the use of cutting-edge technologies, innovative materials and attention to functional design - all these aspects gave life to a range of products of the highest quality, which perfectly adapt to any environment making your everyday work easier.

100% MADE IN ITALY

Gustotek designs and manufactures all its products in Italy, implementing Lean production processes, always respecting the surrounding environment and health. The elimination of waste enhances fluidity and speed in the supply cycle of our products all over the world.





GT LINE

PROFESSIONAL MACHINES TO PRODUCE FRESH PASTA

Machines with a simple and intuitive use that hides advanced technology. A versatile and quick solution, which allows anyone to produce fresh pasta in a short time, satisfying the most diverse requests in terms of type and dough.

With a few operations GT Line machines are able to automatically produce different types of pasta such as long, short and sheet pasta. A high-performance, safe, long-lasting range of machines.

IDEAL FOR:
Restaurants, Pasta shops, Pasta factories and Take Away
Anyone who wants to produce and offer real Italian fresh pasta



Easy
to use and
clean



Quick
with low energy
consumption



Reliable
designed to last
long in time



PERFECTION IN EVERY DETAIL

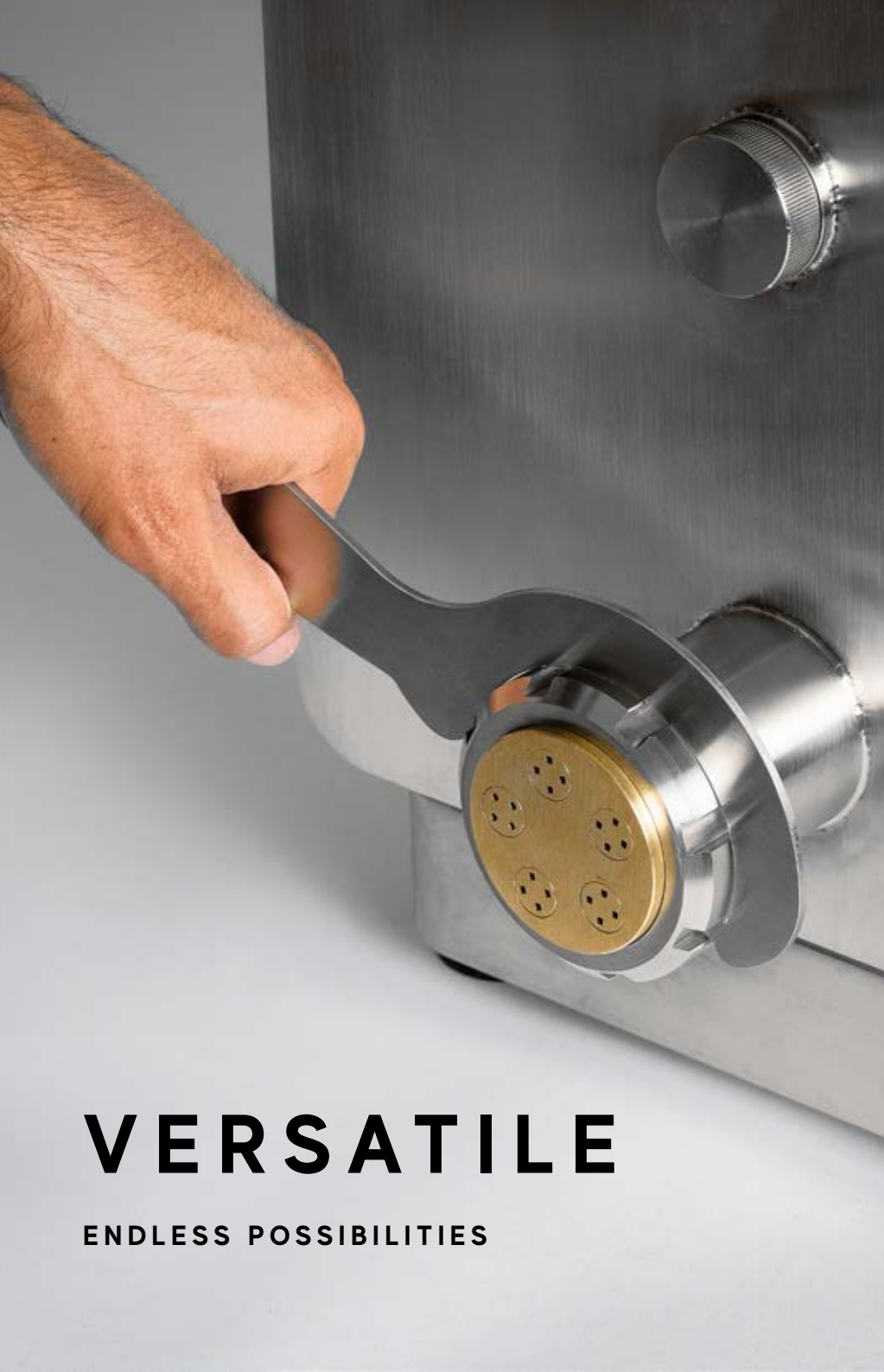

VERSATILE

ENDLESS POSSIBILITIES

**UNLEASH YOUR IMAGINATION.
MAKE YOUR MENU UNIQUE**

By combining your imagination with the infinite possibilities offered by the use of our dies range, you can, for example, prepare in a very short time: green lasagna, red fusilli, macaroni, wholemeal pasta, bigoli, spaghetti alla chitarra, tagliolini, pappardelle and much more.



SPAGHETTI



TAGLIATELLE



FUSILLI



BIGOLI



LINGUINE



... AND MUCH MORE





TECHNOLOGIES

THAT SIMPLIFY EVERYDAY WORK

PATENT

A NEW LEVEL OF PERFORMANCE

GT UPPER

The adaptability of GT Line machines guarantees the possibility to easily and quickly increase the productivity up to 8 kg when kneading thanks to the KGT006 and KGT008 kits. Doing so, your machine can follow the development and growth of your business and adapt to the changes in production demands.

GT KLEAN

Maximum hygiene. Thanks to the FAST GT LINK system, the tank for dough kneading can be easily placed into your dishwasher, ensuring the absolute cleanness of all parts of the machine which are in contact with the dough and, at the same time, eliminating the time-consuming manual cleaning process required for different machines.

GT DESIGN

The minimalist aesthetics in combination with the attention to details during the production phase makes GT Line the main object in any culinary show. The production of fresh pasta in such contexts as ceremonies, parties, restaurant shows becomes an interesting highlight and a pleasure to show.

GT INOX

The quality of the used materials is clearly visible when looking at the tank for dough kneading, which is completely made of AISI 304 stainless steel complying with the most stringent hygiene standards. The machine chassis is also made of stainless steel to ensure the longest service-life to our customers, even under harsh conditions and, of course, to facilitate the operations for its cleaning.

GT GEAR

Advanced technology and innovative components. The transmission system is controlled by the steel toothed-wheel and moto-gear reductor. Thus, the belt pulley and chain transmission have been eliminated in order to ensure the machine best reliability in time.

GT STANDARD

Using 63,5 mm diameter dies, which is the recognized standard in the fresh pasta extrusion market, makes it possible to use units from various manufacturers, as well as to reuse already existing dies. The flexibility and simplicity in the dies replacement ensure the effective production of various types of pasta.

GT SILENT

Noiselessness. Operators are often afraid of additional noise, vibrations and disturbances in the surrounding environment because the acoustic pollution can become a factor of low-level comfort for those working nearby the machine. GT Line Body is completely sound-proofed in order to minimize noise in your kitchen.

GT SMART

Technological, performing but at the same time easy to use and, above all, versatile. GT Line machines transform a complex process into a simple operation, available to everyone. A "smart machine", which makes even the daily cleaning operations simple, thanks to the tank that can be easily removed and washed in your dishwasher. GUSTOTEK is also a project focused on new eating habits, designed to give the possibility to quickly use two separate tanks for two types of dough. This option helps avoid flour contamination to meet the needs of customers with food allergies or intolerances.

DETAILS THAT MAKE THE DIFFERENCE

GT LINE machines are not only attractive and easy to use, but built with the most advanced materials and techniques. They are equipped with safety devices. Extremely reliable, productive and easy to clean, they make every gesture simple, during and after its use. They always guarantee a perfect extrusion result.



Intuitive and easy user interface



Robust chassis in AISI 304 stainless steel



Removable tank easy to put into your dishwasher



Lid slot for safe pouring of liquids



Compatibility with standard 63.5 mm dies



Pasta cuttler with speed variator

* The products manufactured by GUSTOTEK are protected by a patent for industrial invention with the following title: Extrusion mixing machine for food products with removable elements

MODELS AND TECHNICAL FEATURES

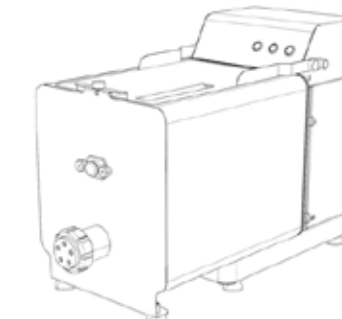
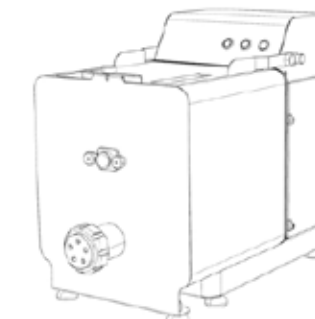
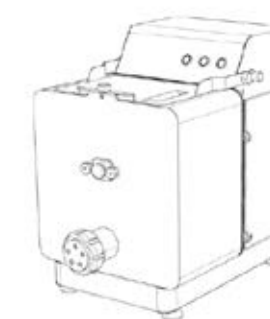

Model	GT104M	GT104	GT106	GT108
Motor	0,75 kW 220-240V 50Hz	0,55 kW 400V 50Hz	0,55 kW 400V 50Hz	0,55 kW 400V 50Hz
Ø dies	63,5 mm	63,5 mm	63,5 mm	63,5 mm
Kg/h	from 12 to 16	from 12 to 16	from 14 to 18	from 16 to 20
Dimensions	330 x 470 x 420 (mm)	330 x 470 x 420 (mm)	330 x 470 x 520 (mm)	330 x 470 x 620 (mm)
Net Weight	51,5 kg	49,5 kg	53,5 kg	57,5 kg
Standard Accessories	KTL001	KTL001	KTL001	KTL001

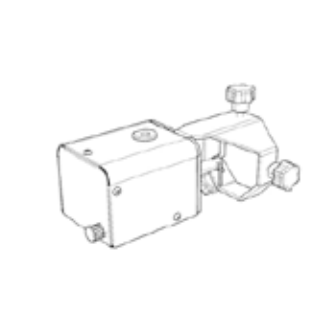
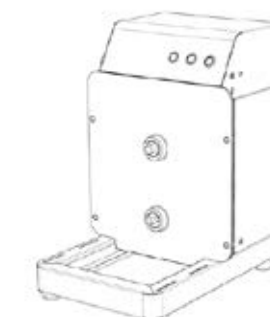
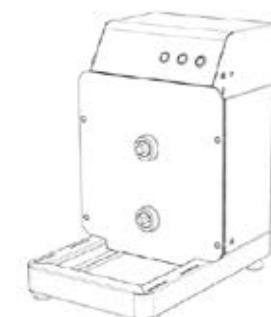

Model	GT100M	GT100	KTL001	GRA100
Motor	0,75 kW 220-240V 50Hz	0,55 kW 400V 50Hz	24V DC	-
Ø dies	-	-	-	-
Kg/h	-	-	-	-
Dimensions	330 x 470 x 420 (mm)	330 x 470 x 420 (mm)	110 x 95 x 216 (mm)	530 x 630 x 950 (mm)
Net Weight	39,5 kg	37,5 kg	1,7 kg	24 kg
Standard Accessories	-	-	-	-

GUSTOTEK™

GUSTOTEK SRL
Via Fortunato Zeni, 8 - 38068 Rovereto (TN)
P.I.(VAT): 02429020221

WWW.GUSTOTEK.CLOUD

FOLLOW US ON   